

T 2538 EN Self-operated Pressure Regulators · Type 2404-1

Pressure Reducing Valve with Pilot Valve for small set point ranges



Application

Pressure reducing valve for set points from **0.045 to 1.5 psi/3 to 100 mbar** · Nominal size **NPS 1 to 6/DN 25 to 150** · **Class 125, 150, 300/PN 16 to 40** · Suitable for gases at temperatures from **-5 to 195 °F/-20 to +90 °C**

The valve **closes** when the downstream pressure **rises**.

The pilot-operated Type 2404-1 Pressure Reducing Valve is preferably used for the precise control of inert gas in tank blanketing applications (e.g. when storing oxidation-sensitive, toxic or explosive products). The inert gas (usually nitrogen) is applied to protect the product inside the tank from reacting with the ambient atmosphere.

The Type 2404-1 Pressure Reducing Valve regulates the excess pressure of the inert gas to a constant pressure within the millibar range.

The pressure regulator ensures that the pressure in the tank remains constant during pumpout operations. Furthermore, adverse weather conditions, e.g. a sudden temperature drop, can affect the pressure inside the tank. In both cases, inert gas flows into the tank until the pressure reaches adjusted set point.

Special features

- Low-maintenance proportional regulator
- Pilot control provides excellent control accuracy
- Internal set point springs
- Soft-seat plug provides bubble-tight shut-off performance
- Meets strict fugitive emission requirements
- Suitable for sour gas service (NACE)

Versions

The Type 2404-1 Pressure Reducing Valve is a pilot-operated regulator.

The regulator consists of the following components:

Type 2406 as main valve

- NPS 1 to 6/DN 25 to 150, balanced by a diaphragm

Type 2405 Pilot Valve

- ½ NPT female thread, C_v 1.2/ K_{VS} 1.0

Type 44-1 B Input Pressure Regulator

- With NPT female thread; C_v 1.2/ K_{VS} 1.0



Fig. 1: Type 2404-1

Mounting kit M2404, consisting of:

- Hook-up, needle valves etc.

Special versions

Version with FDA-compliant materials for the food processing and pharmaceutical industries · Versions for sour gas service (NACE) · Actuator of pilot valve with seal and leakage line connection (e.g. for flammable gases)

Principle of operation

The Type 2404-1 Pressure Reducing Valve is a pilot-operated regulator. It regulates the supply pressure of the inert gas within the millibar range to a low pressure, creating a constant blanketing of the product inside the tank.

The following components interact to regulate the pressure of the inert gas.

The input pressure regulator (3) is delivered ready-adjusted. It reduces the upstream pressure p_1 to the input pressure p_e for the pilot valve (2) to approx. 1 bar (positive pressure), ensuring precise pressure control even at varying upstream pressures. The pilot valve governs the control pressure p_s for the main valve (1) and corrects the set point.

The needle valve (4) is delivered ready-adjusted and lead-sealed.

If the pressure in the tank drops slightly below the set point pressure, for example due to the product being withdrawn from the tank, the pilot valve (2) is opened by the preloaded set point spring (2.1). As a result, the control pressure p_s acting on the actuator diaphragm (1.3) of the main valve (1) increases. The main valve opens, causing the inert gas to flow into the tank until the inert gas blanket is re-established or the set point pressure is reached again.

When the pressure in the tank increases constantly, for example during filling, the pressure in the actuator chamber (1.2/2.2) of the pilot valve and main valve increases. The pilot valve (2) closes when the pressure increases above the pressure set point. The control pressure p_s does not have any effect in this case. The main valve is closed by the actuator springs (1.1) and the increased inert gas pressure p_2 .

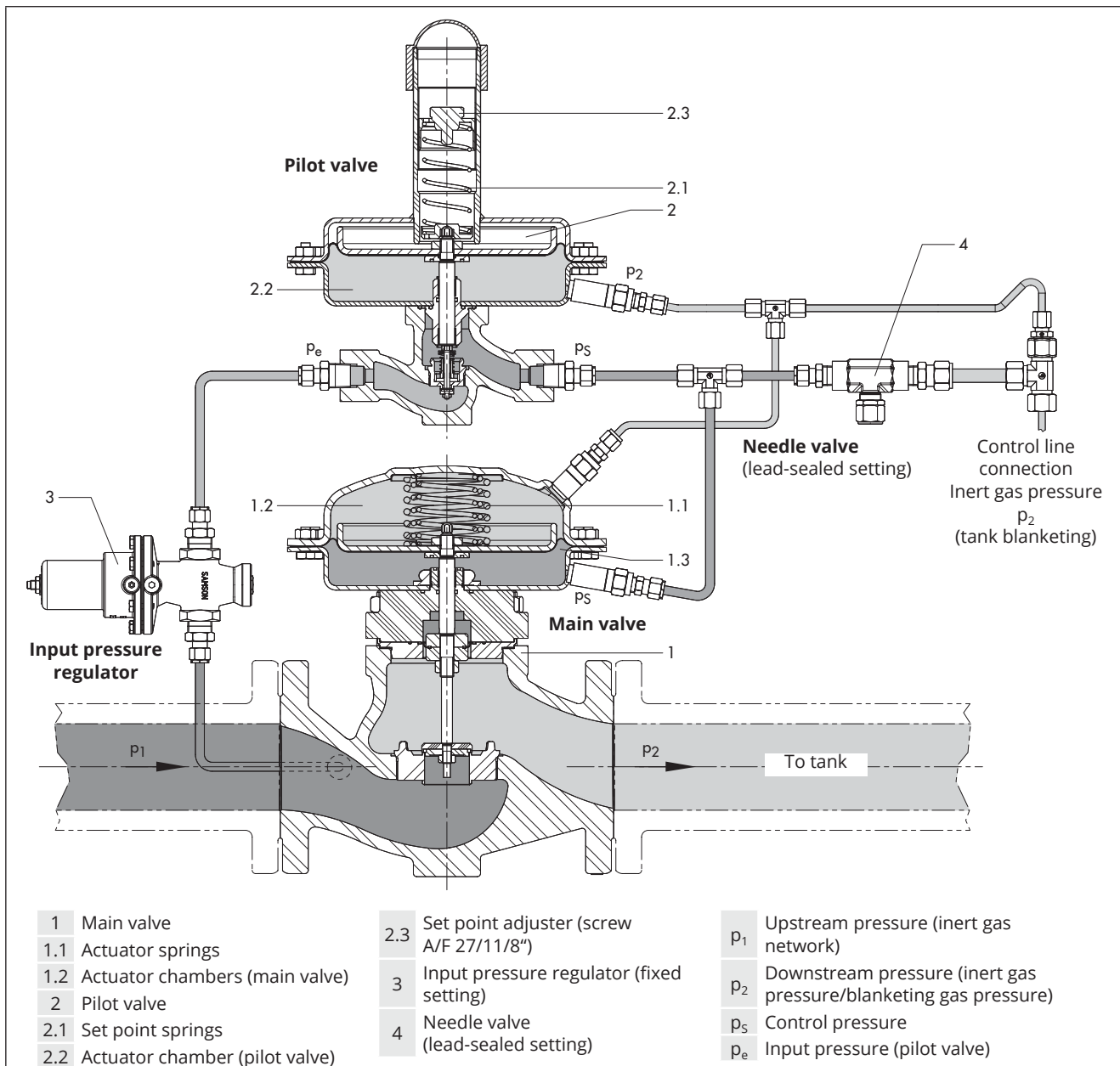



Fig. 2: Functional diagram of Type 2404-1

Technical data

Table 1: Type 2404-1 Pressure Reducing Valve

Type 2406 as main valve, balanced by a diaphragm							
Nominal size ⁴⁾	NPS 1 DN 25	NPS 1½ DN 40	NPS 2 DN 50	NPS 2½ DN 65	NPS 3 DN 80	NPS 4 DN 100	NPS 6 DN 150
Pressure rating	Class 125, 150 and 300/PN 16 to 40						Class 125 and 150/ PN 16 to 40
C _v coefficients	9.4	23	37	60	94	145	450
K _{vS} coefficients	8.0	20	32	50	80	125	380
Reduced C _v coefficient	-	9.4		23	37	94	-
Reduced K _{vS} coefficient	-	8.0		20	32	80	-
C _v with flow divider ¹⁾	-	-		45	70	70 · 110	335
K _{vS} with flow divider ¹⁾	-	-		38	60	60 · 95	285
Actuator area	50 in ² /320 cm ²						
Leakage class according to ANSI/FCI 70-2 or IEC 60534-4	Soft-seated, minimum Class IV						
Max. permissible differential pressure	175 psi/12 bar ²⁾						
Min. differential pressure Δp _{min}	15 psi/1 bar						
Perm. temperature	-5 to +195 °F/-20 to +90 °C ³⁾						
Conformity							

¹⁾ Reduced C_v/K_{vS} coefficients with flow divider on request

²⁾ Higher pressures on request

³⁾ Max. 175 °F (80 °C) for EPDM and NBR versions

⁴⁾ DN 32 and DN 125 available on request

Table 2: Type 2405 Pilot Valve

Type 2405 Pilot Valve			
Connection	½ NPT female thread		
Pressure rating	Class 300		
C _v coefficient	1.2		
K _{vS} coefficient	1.0		
Set point ranges	0.045 to 0.15 psi 3 to 10 mbar	0.075 to 0.45 psi 5 to 30 mbar	0.35 to 1.5 psi 25 to 100 mbar
Actuator area	100 in ² /640 cm ²	50 in ² /320 cm ²	50 in ² /320 cm ²
Input pressure p _e	Setting of the input pressure regulator fixed at approx. 15 psi/1 bar		
Perm. temperature	-5 to +195 °F/-20 to +90 °C ¹⁾		
Conformity			

¹⁾ Max. 175 °F (80 °C) for EPDM and NBR versions

Table 3: Materials · Material numbers according to ASTM and DIN EN

Type 2406 as main valve	
Body	A126B, A216 WCC, A351 CF8M · EN-GJL-250, 1.0619, 1.4408
Valve seat	1.4404/316L
Plug	1.4404/316L
Plug seal	EPDM · NBR · FKM
Operating diaphragm, balancing diaphragm	EPDM · NBR ²⁾ · FKM
Internal parts, guiding parts	1.4404/316L
Diaphragm cases	1.0332 (1.4301/stainless steel body)
Actuator springs	1.4310 ¹⁾

¹⁾ Versions for sour gas service (NACE): Hastelloy®

²⁾ Not for NPS 2½, 3 and 4/DN 65, 80 and 100

Table 3: Materials · Material numbers according to ASTM and DIN EN

Pilot valve		Type 2405¹⁾
Body	A216WCC · A351 CF8M	
Valve seat	1.4404/316L	
Plug	1.4404/316L	
Plug seal	EPDM · NBR · FKM	
Operating diaphragm	EPDM · NBR · FKM	
Internal parts, guiding parts	1.4404/316L	
Set point spring	1.4310	
Mounting kit		
Piping	Stainless steel	
NPT screw fittings	1.4404/316L	
Needle valve	1.4404/316L	
Type 44-1 B Input Pressure Regulator	1.4408/A351 CF8M	

¹⁾ Version for sour gas service (NACE) possible

Table 4: Dimensions and weights

Type 2404-1		NPS 1 DN 25	- DN 32	NPS 1½ DN 40	NPS 2 DN 50	NPS 2½ DN 65
L1	Class 125 and 150	7.25"/184 mm	-	8.75"/222 mm	10"/254 mm	10.9"/276 mm
	CI 300	7.75"/197 mm	-	9.25"/235 mm	10.5"/267 mm	11.5"/292 mm
	PN 16/40	6.3"/160 mm	7.1"/180 mm	7.9"/200 mm	9.1"/230 mm	11.4"/290 mm
L2	13.8"/350 mm					
ØD	0.045 to 0.15 psi · 3 to 10 mbar	Ø15"/380 mm, A = 100 in ² /640 cm ²				
	0.075 to 0.45 psi · 5 to 30 mbar	Ø11.2"/285 mm, A = 50 in ² /320 cm ²				
	0.35 to 1.5 psi · 25 to 100 mbar	Ø11.2"/285 mm, A = 50 in ² /320 cm ²				
H¹⁾	EPDM/NBR/FKM	22.1"/560 mm	23.4"/595 mm			24.6"/625 mm
H1		6.5"/165 mm	6.5"/165 mm			6.5"/165 mm
H3		1.73"/44 mm	2.8"/72 mm			3.8"/98 mm
B		8.5"/215 mm	8.6"/225 mm	9.25"/235 mm	9.6"/245 mm	10.2"/260 mm
Weight, approx.		55 lb/25 kg	64 lb/29 kg	71 lb/32 kg	77 lb/35 kg	132 lb/60 kg
Type 2404-1		NPS 3 DN 80	NPS 4 DN 100	- DN 125	NPS 6 DN 150	
L1	Class 125 and 150	11.7"/298 mm	13.8"/352 mm	-	17.75"/451 mm	
	Class 300	12.5"/318 mm	14.5"/368 mm	-		
	PN 16/40	12.2"/310 mm	13.8"/350 mm	15.75"/400 mm	18.9"/480 mm	
L2	13.8"/350 mm					
ØD	0.045 to 0.15 psi 3 to 10 mbar	Ø15"/380 mm, A = 100 in ² /640 cm ²				
	0.075 to 0.45 psi 5 to 30 mbar	Ø11.2"/285 mm, A = 50 in ² /320 cm ²				
	0.35 to 1.5 psi 25 to 100 mbar	Ø11.2"/285 mm, A = 50 in ² /320 cm ²				
H¹⁾	EPDM/NBR	25"/635 mm	26"/660 mm	28.2"/715 mm	29.1"/740 mm	
	FKM			31.7"/805 mm	32.7"/830 mm	
H1	6.1"/155 mm					
H3		3.9"/100 mm	4.7"/120 mm	5.8"/145 mm	6.9"/175 mm	
B		10.8"/275 mm	11"/280 mm			13"/330 mm
Weight, approx.		146 lb/66 kg	165 lb/75 kg	165 lb/75 kg	309 lb/140 kg	

¹⁾ For actuator with A = 100 in²/640 cm²: height H +0.32"/8 mm

Dimensions

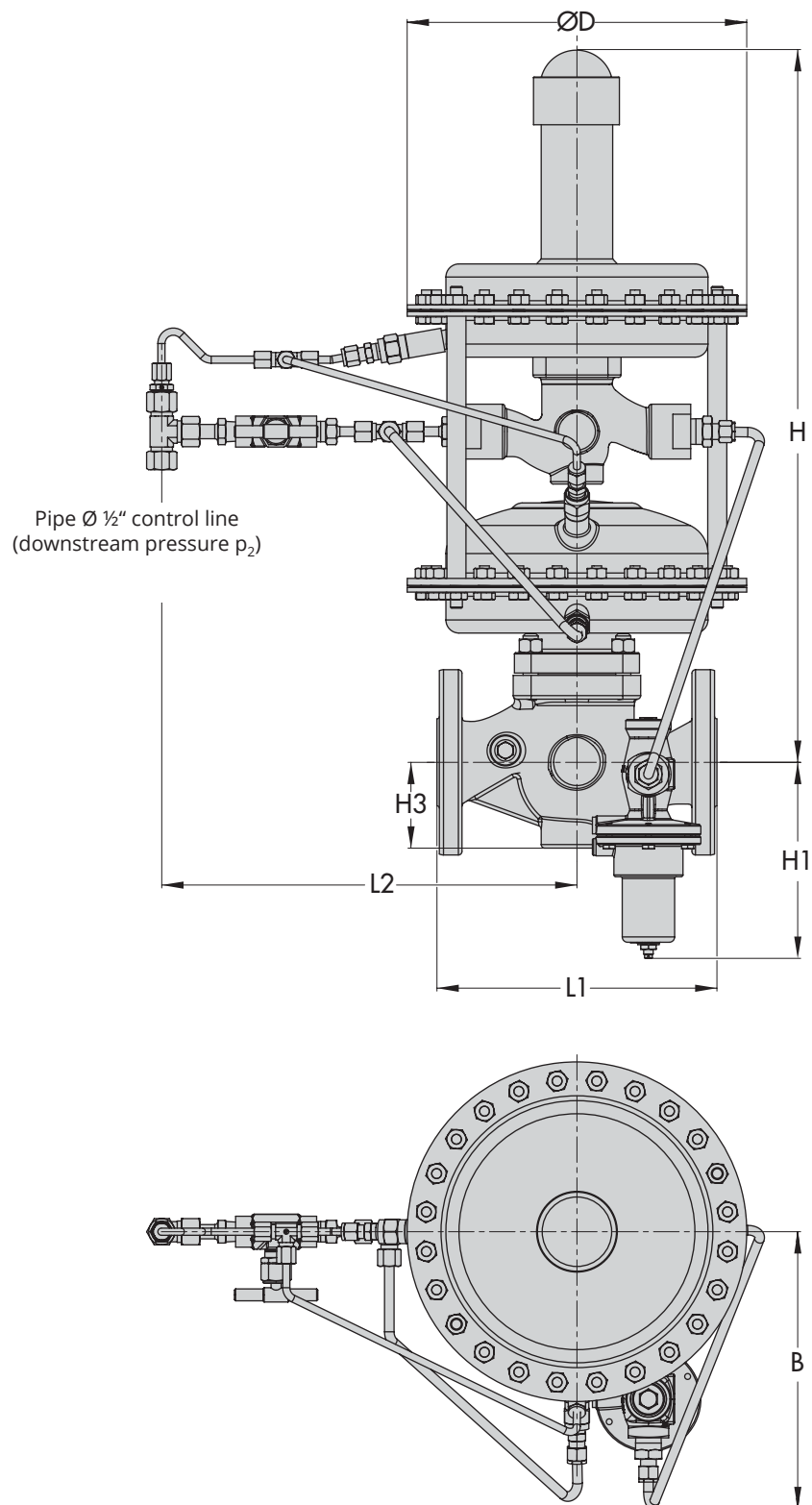

Fig. 3: Dimensions · DN 25 to 100/NPS 1 to 4 · Versions with seal/diaphragm made of EPDM/NBR/FKM

Dimensions

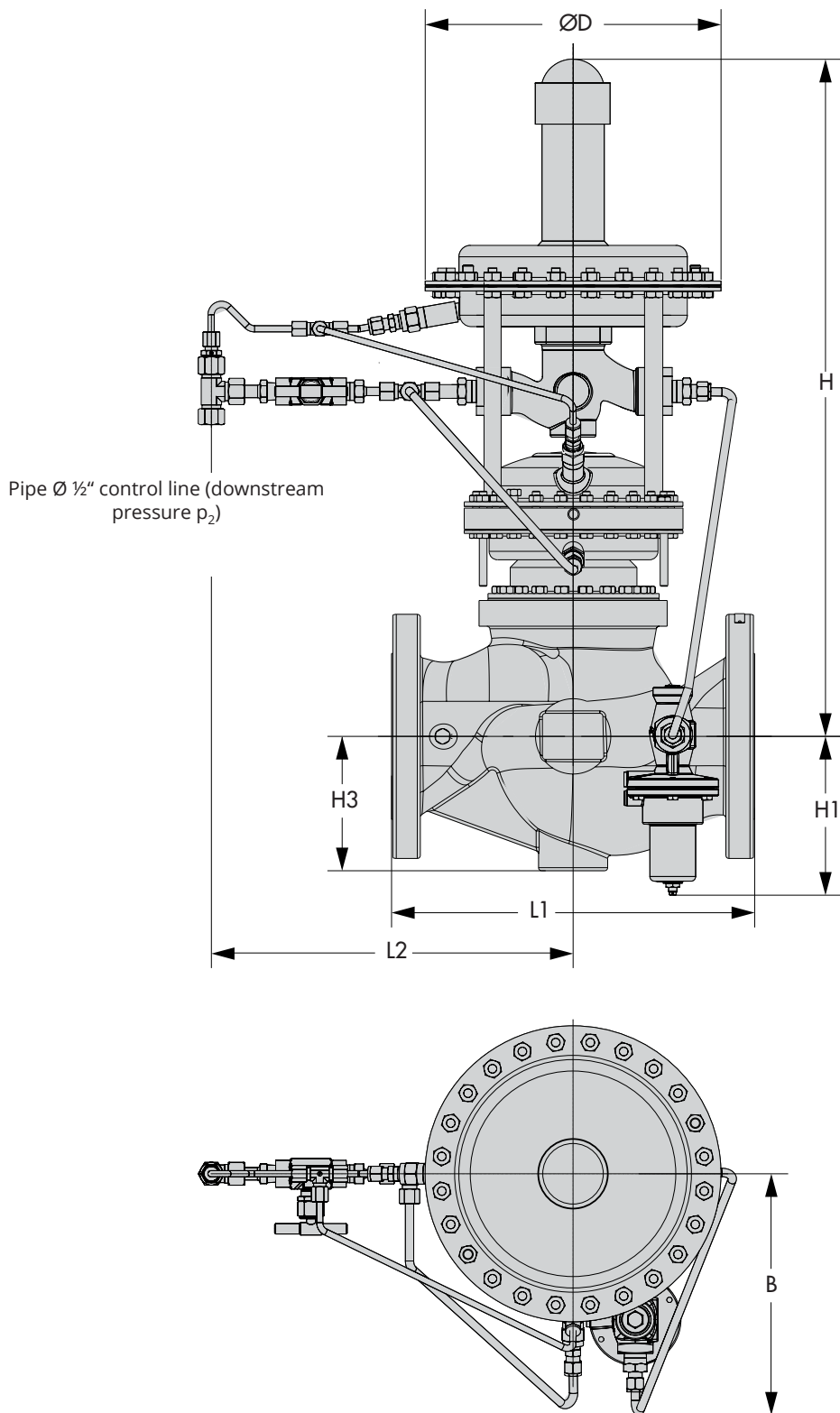

Fig. 4: Dimensions · DN 125 and 150/NPS 6 · Versions with seal/diaphragm made of EPDM/NBR

Dimensions

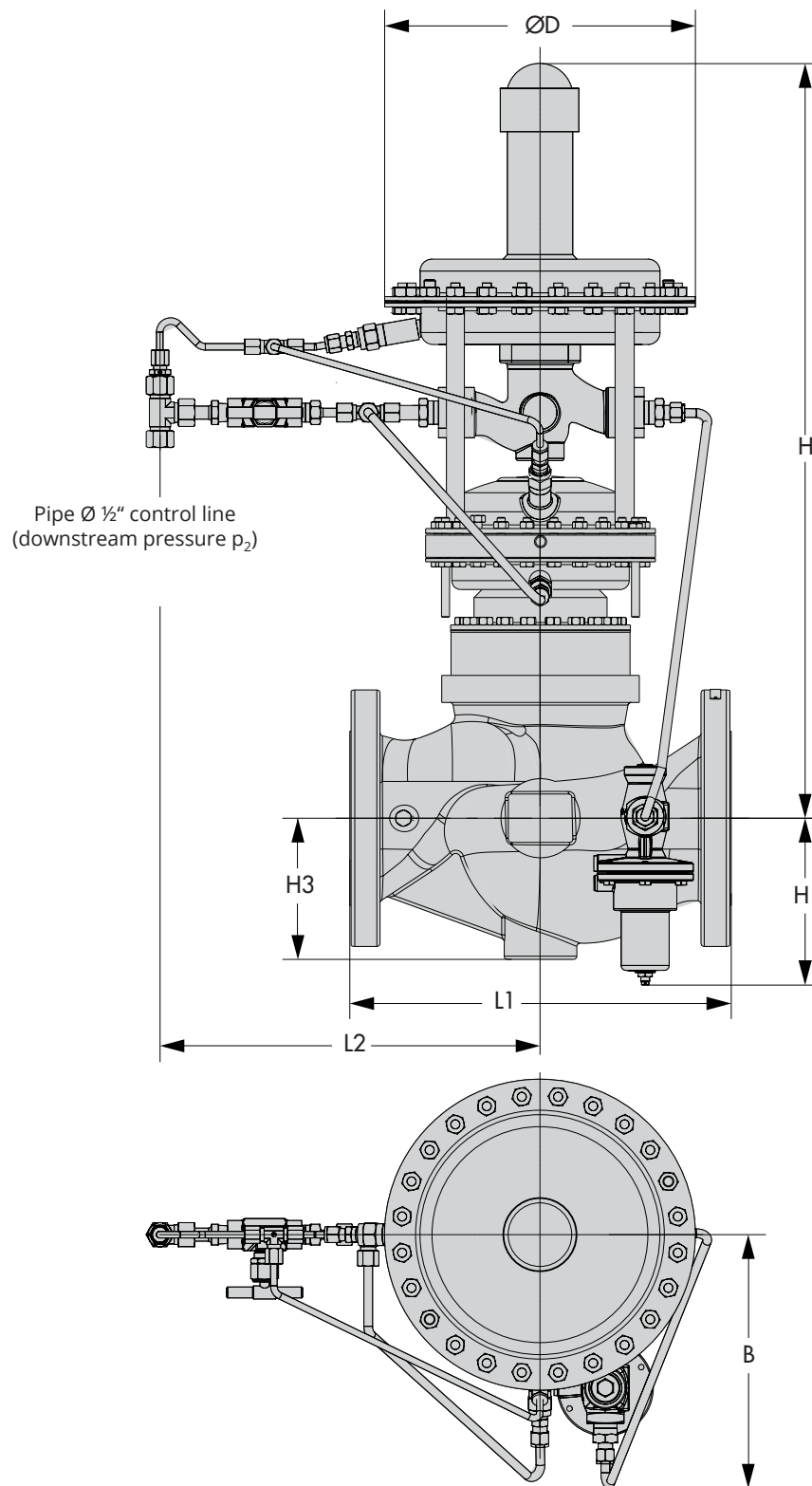

Fig. 5: Dimensions · DN 125 and 150/NPS 6 · Versions with seal/diaphragm made of FKM

Installation

The regulator is delivered as a ready-to-install unit.

- Install the main valve in the pipeline at the site of installation and connect the control line (inert gas pressure p2) to the pilot valve (pipe \varnothing 1/2").



Install the regulator in such a way that it is still easily accessible after the plant is completed to facilitate maintenance or revision work.

Allow enough space for set point adjustment at the pilot valve using a socket wrench.

The following points must be observed:

- Installation in horizontal pipelines
- Install the valve assembly with the pilot valve pointing up
- The direction of flow must match the arrow on the body of the main valve

More details in ► EB 2538.

Ordering text

Type 2404-1 Pressure Reducing Valve consisting of:

Type 2406 functioning as the main valve:

Body material ...

Material: diaphragm ..., plug stem ...

NPS/DN ..., C_v/K_{vs} coefficient ...

Type 2405 Pilot Valve:

Set point range 0.045 to 0.15 psi · 0.075 to 0.45 psi · 0.35 to 1.5 psi/3 to 10 mbar · 5 to 30 mbar · 25 to 100 mbar

Type 44-1 B Input Pressure Regulator

Mounting kit M2404